

# SPECIFICATION

## D-Helix™ High Gain Foldable Antenna

Model: HX-CHX602A

### \* PICTURE AND DIMENSIONS

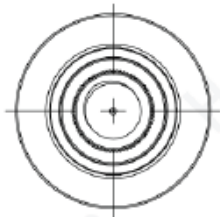

BOTTOM VIEW

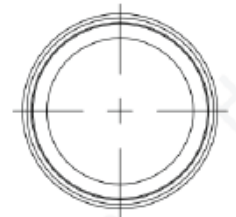

TOP VIEW

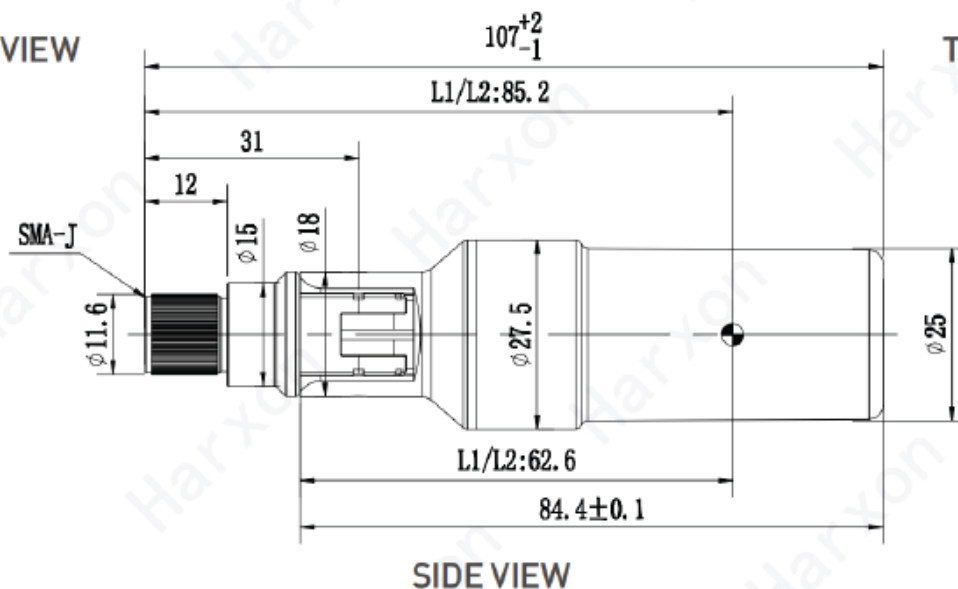

SIDE VIEW

Undeclared Tolerance:  $\pm 0.3\text{mm}$

## × Electrical Characteristics

ITEM		Specifications
Part Number		HX-CHX602A
Antenna	Frequency Range	GPS L1/L2/L5 GLONASS G1/G2/G3 GALILEO E1/E5a/E5b/E6 BDS B1/B2/B3
	Polarization	RHCP
	Peak Gain	2dBi
	Axial Ratio	<3dB
	Azimuth Coverage	360
	Output VSWR	<2.0
	Normal Impedance	50 Ω
	connector	SMA-Male
	Antenna size	25 x 107mm / φ11.6 ; φ25
Low Noise Amplifier	LNA Gain	33 +/-2dB
	Noise Figure	<2dB
	Output VSWR	<2.0
	Passband Ripple	+/-2dB
	Operation Voltage	+3.3 to +12VDC
	Operation Current	<55mA
	Operating Temperature / Storage	-40℃~+80℃ / -55℃~+80℃

# D-Helix™ Antenna HX-CHX602A

## High Gain Foldable Helix Antenna for Surveying

**Harxon**  
a **BDS**Star company

Harxon HX-CHX602A helix antenna is a multi-constellation full frequency high gain geodetic surveying antenna. This small form factor antenna employs a foldable design that allows a maximum of 90 degree bending angle for superior GNSS signal availability while integrated with surveying terminals as pad and consoles in the field. Its high sensitivity, low power consumption, small dimensions, flexible angle of signal reception make it a great match for geodetic surveying applications



### HIGH PHASE CENTER STABILITY

The Harxon HX-CHX602A offers full support for reliable and consistent satellite signals tracking, including GPS, GLONASS, Galileo and BeiDou, as well as L-Band. It also exhibits a very stable phase center by adopting multipoint feeding technology, exceptional low elevation satellite tracking with symmetric radiation patterns, high gain with ultralow signal loss, as well as outstanding wide-angle circular polarization (WACP) ensures remarkable positioning accuracy.

### TRACKING IN CHALLENGING ENVIRONMENTS

The HX-CHX602A is able to track any visible satellites under challenging conditions, providing the positioning solutions with higher precision and reliable data. The ability to track low elevation satellites while maintaining high gain makes this antenna an excellent choice for any applications where the sky is partially visible, such as plant protection, tree canopy, or for UAV power patrol, GIS surveying where high precision is needed.

### STRONG ANTI-INTERFERENCE PERFORMANCE

The advanced LNA (Low Noise Amplifier) excels in improved signal filtering and out-of-band rejection and restrains unwanted electromagnetic interferences, plus strong multi-path reduction capacity over all GNSS frequency bands, providing strong anti-interference performance for consistent and reliable GNSS signals, even under complicated environments such as power grids, communication base stations or radio.

### SMALL FORM FACTOR FOLDABLE DESIGN

HX-CHX602A adopts a rugged small form factor foldable design that allows a maximum of 90 degree bending angle, providing the most flexible GNSS signal reception angle for robust signal availability of the surveying control terminals. This foldable design ensures reliable performance even after long-term repeated bending operations. The Harxon patented IP65 waterproof enclosure ensures the antenna long term reliable performance even under harsh environments as rain, dust, splash or sunlight.

### KEY FEATURES

- Multi-constellation Full Frequency and L-Band Support
- Reliable Phase Center for Millimeter Positioning Accuracy
- Excellent Anti-interference Performance
- Small Form Factor with Foldable Design
- IP65 Rating Waterproof

## × Gain Radiation Pattern Test

File No: \_\_\_\_\_

### 1、 Test Purpose

This test is testing the performance of the passive gain radiation pattern of the CHX602A antenna.

### 2、 Test Equipment

Microwave anechoic chamber, vector network analyzer, test cables, and fixed fixtures.

### 3、 Test Results

#### 3.1 Gain Test Data

Frequency	Peak gain (dBic)
BDS B2	-3.06
GPS L2	2.25
GLONASS L2	-0.67
BDS B1	-2.65
GPS L1	2.48
GLONASS L1	0.55

File No:

3.2 CHX602A antenna gain radiation pattern and axial ratio test result

BDS-B2 Gain Radiation Pattern

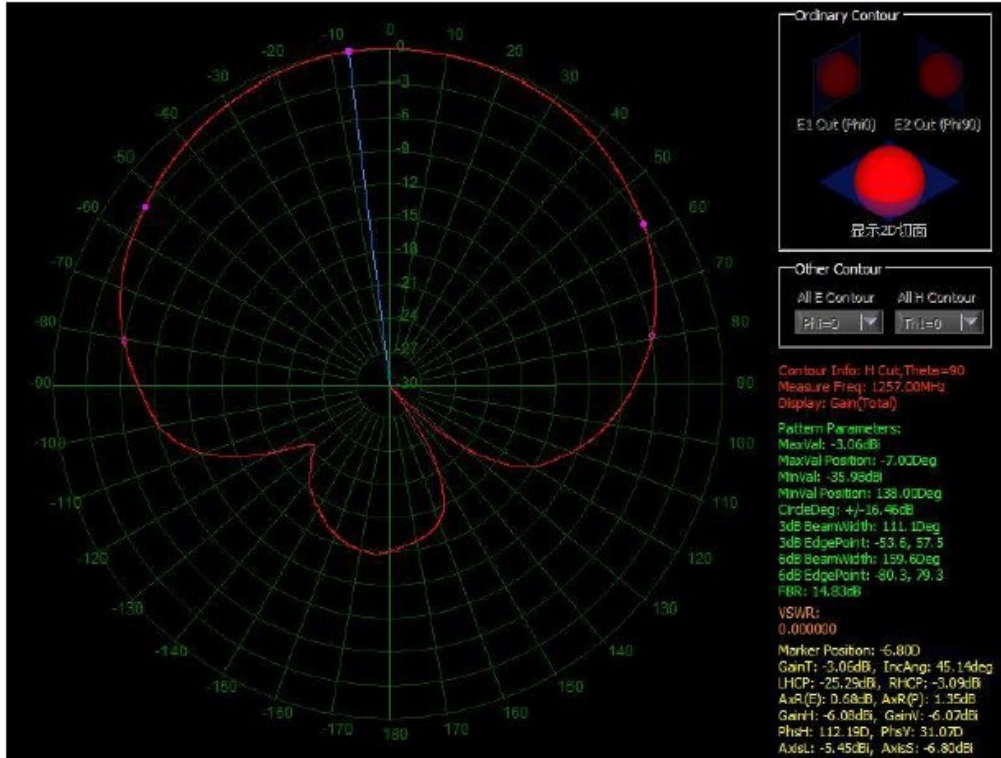

BDS-B2 Axial ratio test result

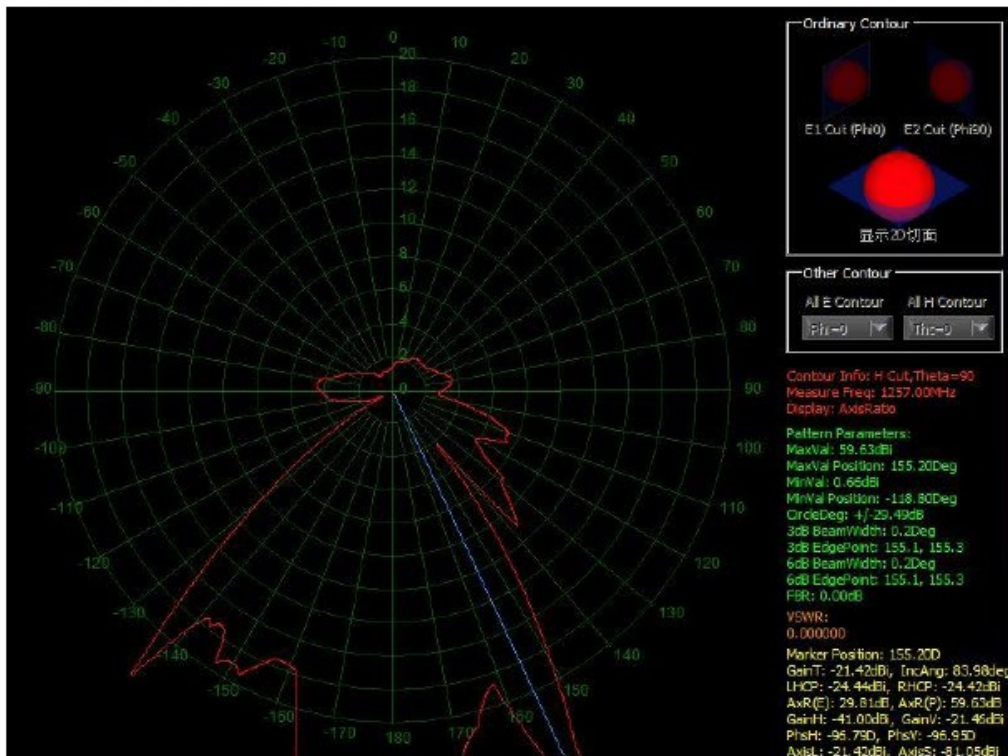

File No:

**GPS-L2 Gain Radiation Pattern**

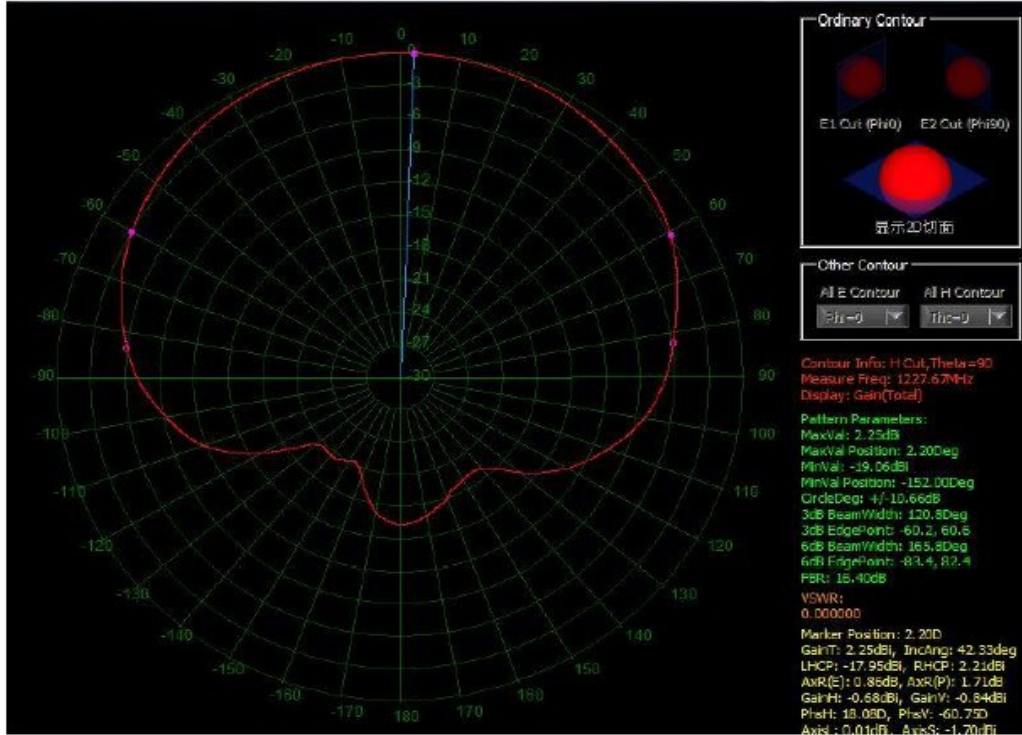

**GPS-L2 Axial ratio test result**

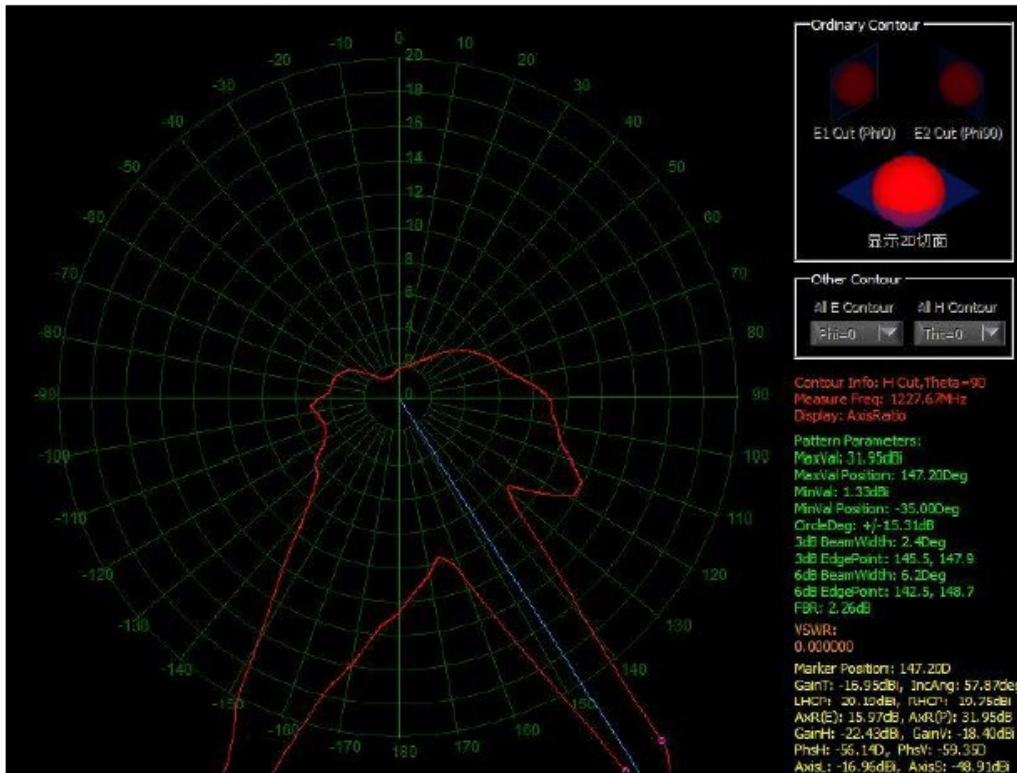

File No:

**GLONASS-L2 Gain Radiation Pattern**

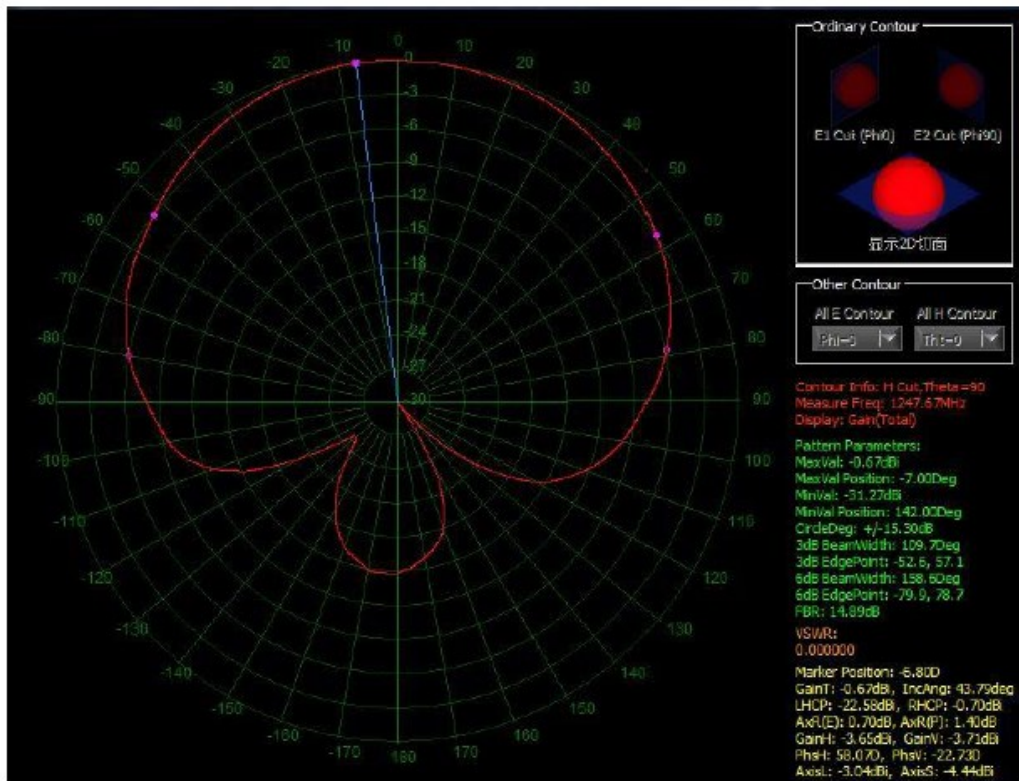

**GLONASS-L2 Axial ratio test result**

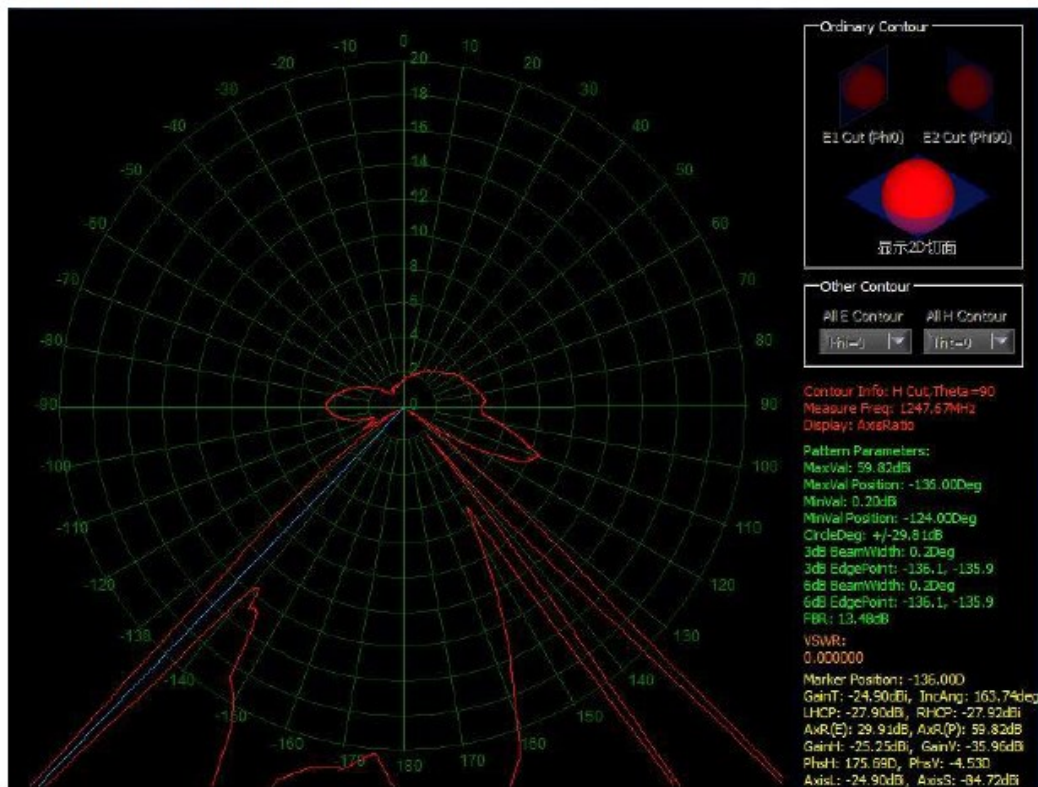

File No:

BDS-B1 Gain Radiation Pattern

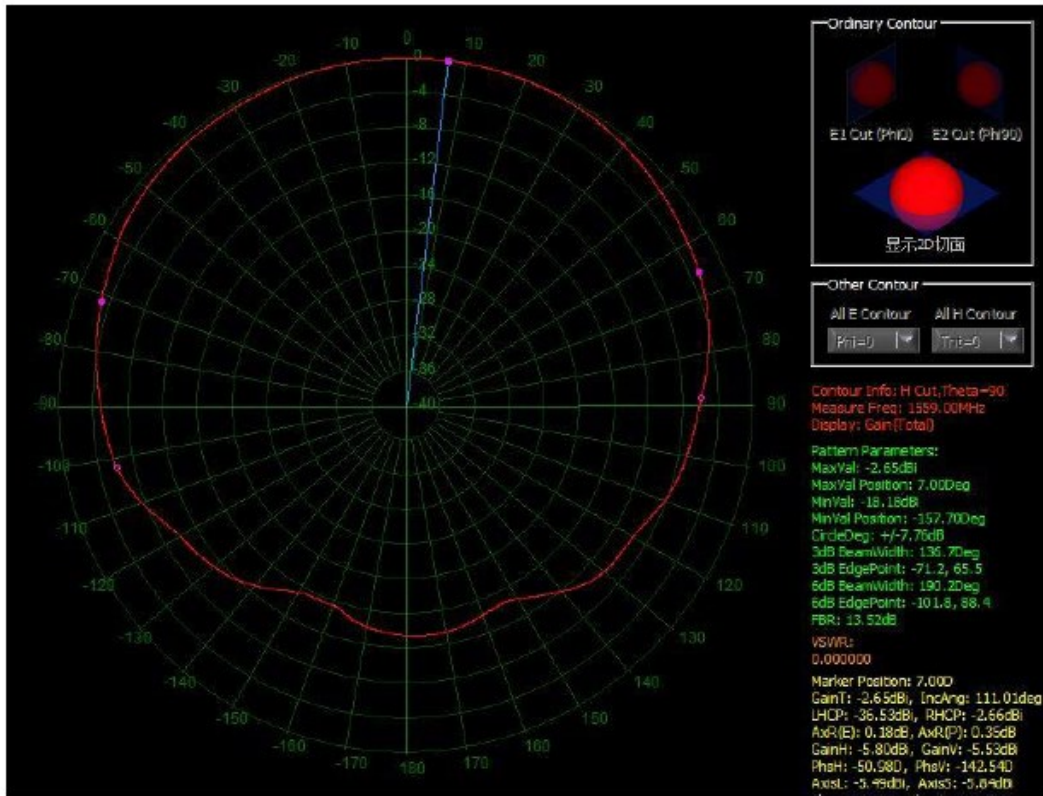

BDS-B1 Axial ratio test result

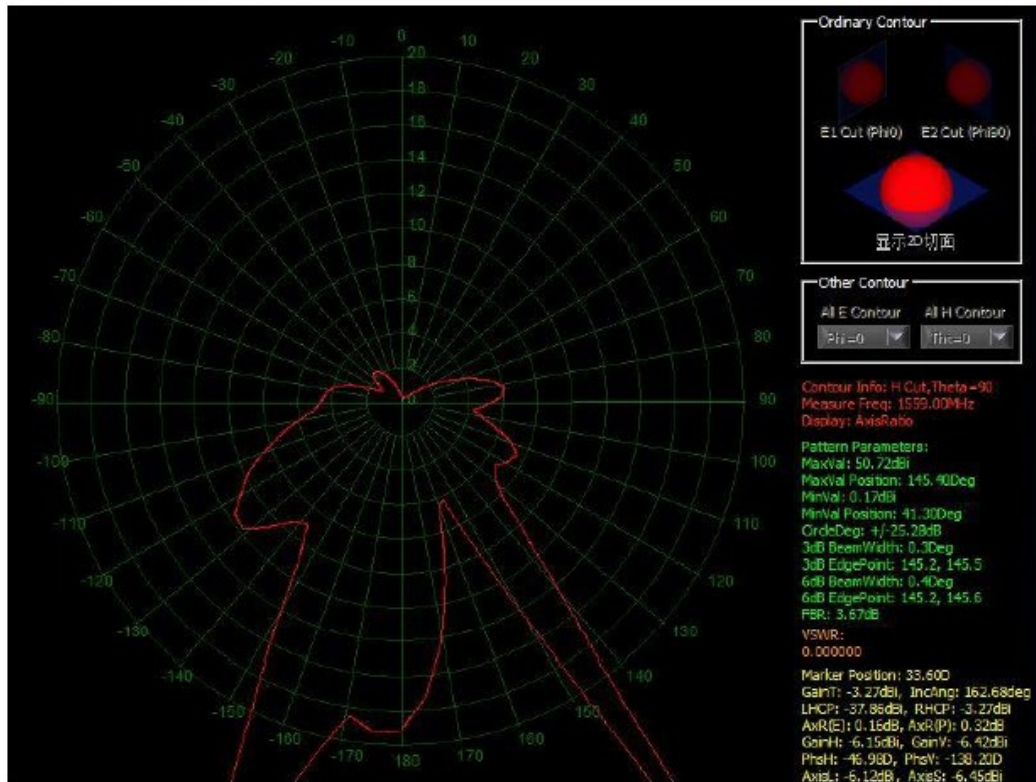



File No:

GPS-L1 Gain Radiation Pattern

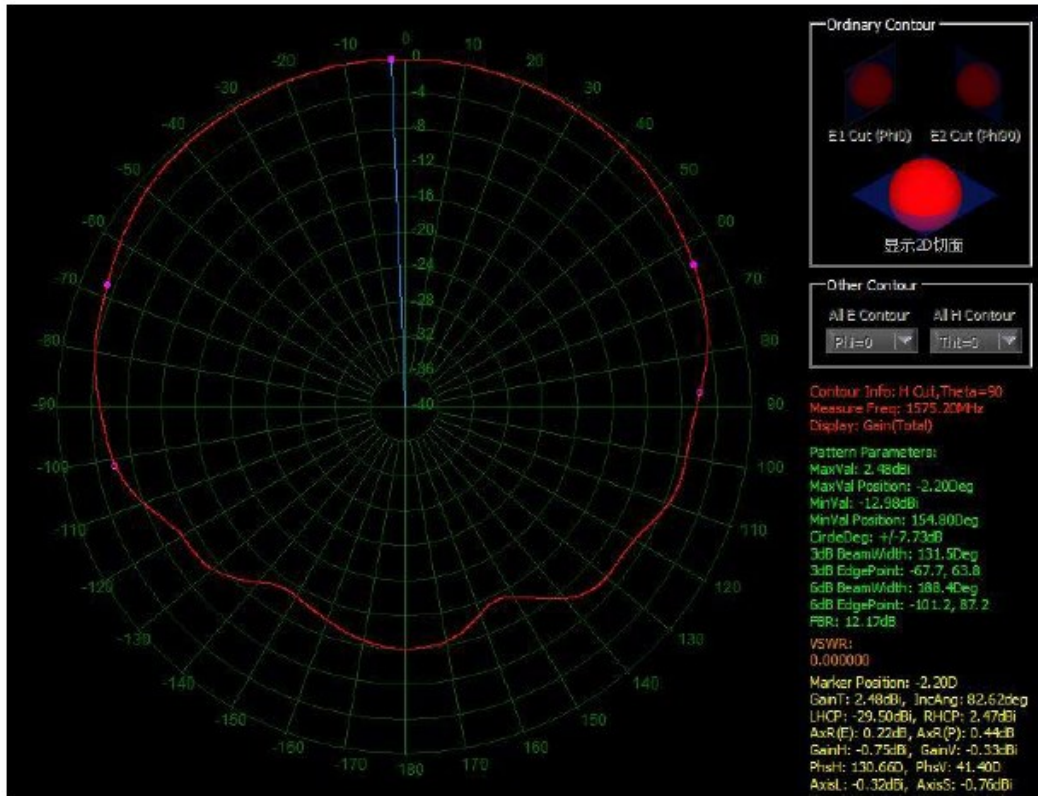

GPS-L1 Axial ratio test result

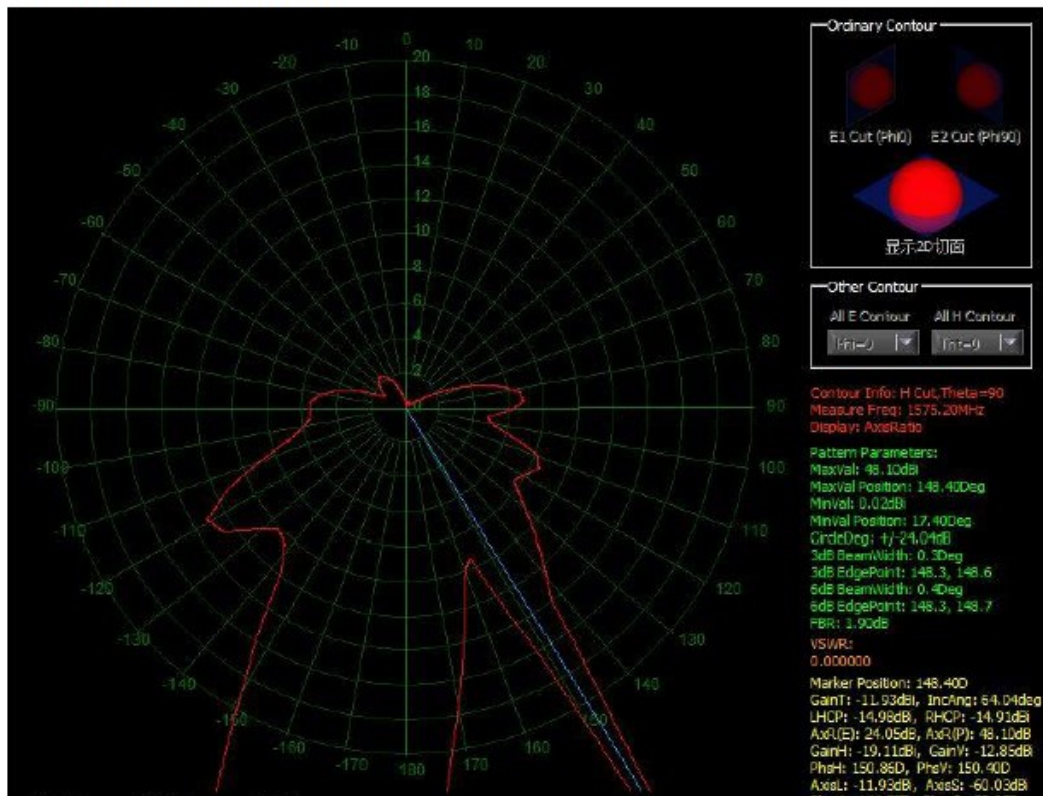

File No:

**GLONASS-L1 Gain Radiation Pattern**

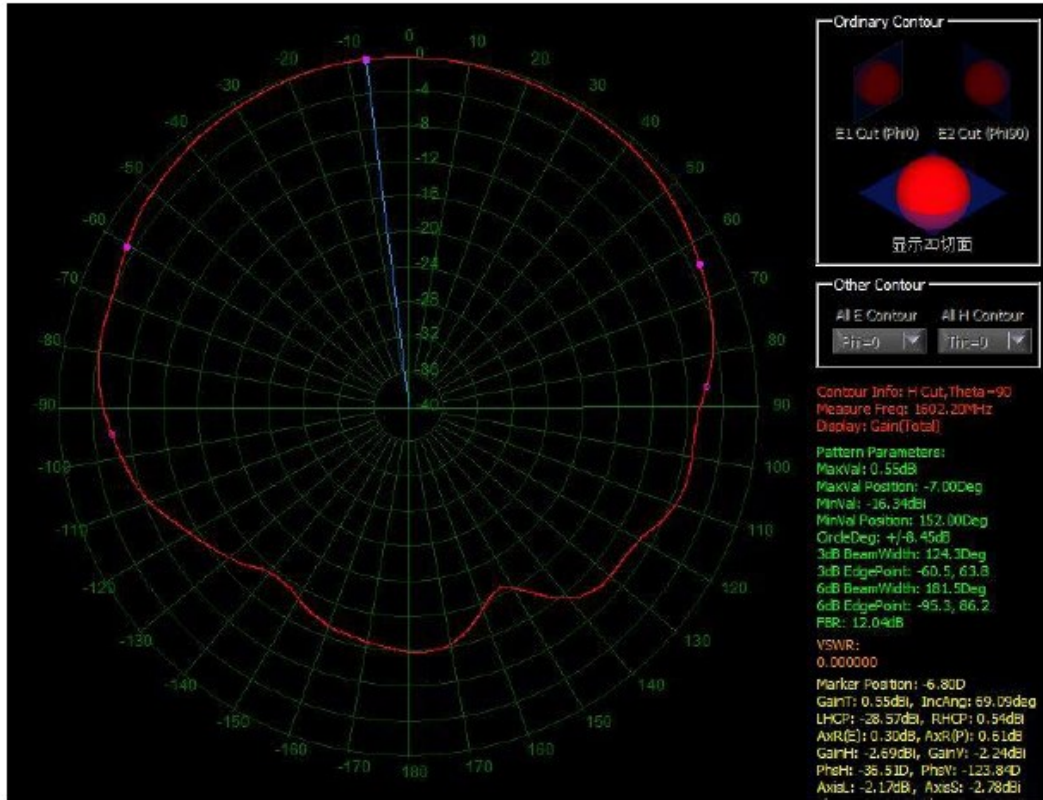

**GLONASS-L1 Axial ratio test result**

